

HPM200 CWS Short Mast



Base

Model	CAT 330	
Engine model	CAT C7.1	
Power rating ISO 14396	205 kW	275 hp
Displacement	7.01 l	428 in ³
Fuel Tank	474 l	125.2 gal

Undercarriage

Undercarriage Type	Variable Width	
Width:	3000 - 4270 mm	9'10" - 14'
Shoe Width:	720 mm	2'4"

Rotary

Rotary Torque	295 kNm	217500 lb.ft
Max Effective Torque	251kNm	185000 lb.ft
Working Speed	9-24 rpm	
Working Gears	10	
Discharge Speed	50-120 rpm	
Discharge Gears	10	

Main Winch

Max Pull Force	230 kN	51700 lbf
Starting Pull Force	250 kN	56200 lbf
Rope Speed	70 m/min	230 ft/min
Rope Diameter	28 mm	1 1/8"

Auxiliary Winch

Max Pull Force	115 kN	26000 lbf
Rope Speed	55 m/min	180 ft/min
Rope Diameter	22 mm	7/8"

Crowd System

Crowd Type:	Winch Crowd Pull	
Pull Force:	310 kN	70000 lbf
Push Force	200 kN	45000 lbf

Drilling Data

Standard Kelly bar:	6/18	
Drilling Depth:	18 m	60 ft
Drilling Diam.:	2200 mm	7 ft 2 in
Max Drilling Diam.:	4000 mm	13 ft

**Different Kelly-Bar available on request*

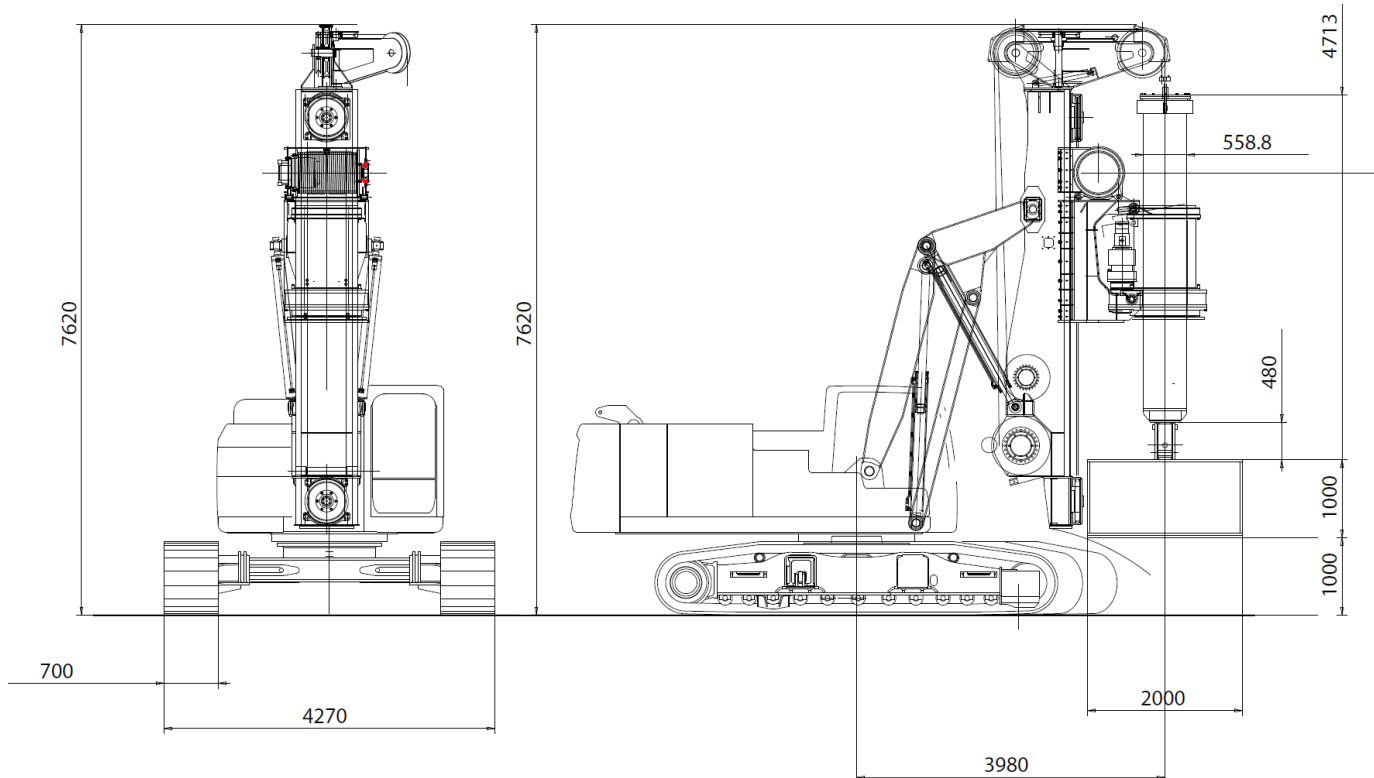

Operating Weight

Weight with 6/18 KB 48.2 ton
 106200 lb

Transport Weight

Without KB, rotary, counterweights 33 ton
 73400 lb

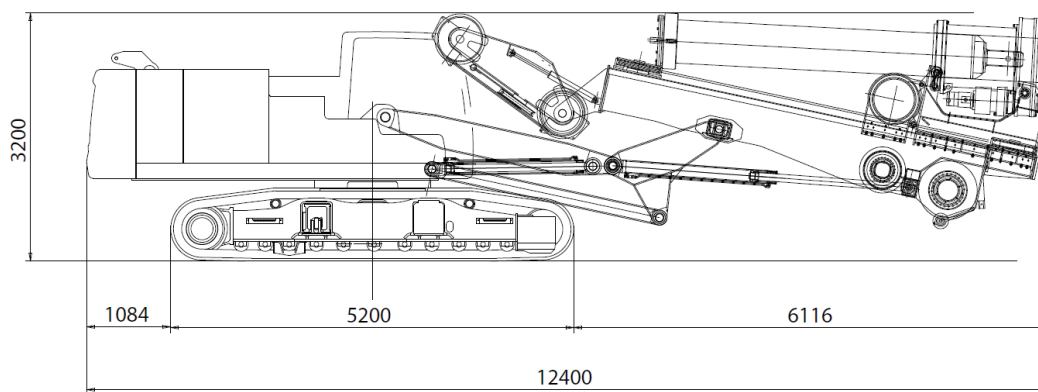

MAIN STANDARD EQUIPMENT

- Multifunctional HPM Computer
- Travel Alarm
- Cameras
- Automatic Mast Verticalization
- Auto Alignment with memory function
- Rotary Speed Control
- 10 Gears System
- Remote Diagnostics/Updates
- Removable Counterweight
- Extendable Undercarriage

OPTIONAL EQUIPMENT

- Aux. Swing Brake
- Casign Oscillator Predisposition
- Universal Casing Joint
- Walking Platform
- Remote Control
- Self Erecting Counterweight
- Biodegradable Hydraulic Oil
- Central Lubrication System
- Long Mast Kit

Design developments and process improvements may require the specification and materials to be updated and changed without prior notice or liability.

These and the technical data are provided as indicative information only, with any errors and misprints reserved.