

HPM 180R



Base

Model	CAT 330	
Engine model	CAT C7.1	
Power rating ISO 14396	205 kW	275 hp
Displacement	7.01 l	428 in ³
Fuel Tank	474 l	125.2 gal

Undercarriage

Undercarriage Type	CAT 330	
Width:	3000 mm	9'10"
Shoe Width:	600 mm	24"

Rotary

Rotary Torque	254 kNm	188000 lb.ft
Max Effective Torque	216 kNm	160000 lb.ft
Working Speed	9-27 rpm	
Working Gears	10	
Discharge Speed	45-110 rpm	
Discharge Gears	10	

Main Winch

Max Pull Force	180 kN	40000 lbf
Starting Pull Force	205 kN	46000 lbf
Rope Speed	70 m/min	230 ft/min
Rope Diameter	24 mm	15/16"

Auxiliary Winch

Max Pull Force	75 kN	16900 lbf
Rope Speed	80 m/min	260 ft/min
Rope Diameter	15 mm	19/32"

Crowd System

Crowd Type:	Cylinder Crowd Pull	
Pull Force:	310 kN	70000 lbf
Push Force	180 kN	40000 lbf

Drilling Data

Standard Kelly bar:	5/42	
Drilling Depth:	13 m	42ft
Drilling Diam.:	1800 mm	6 ft
Max Drilling Diam.:	3000 mm	11 ft

**Different Kelly-Bar available on request*

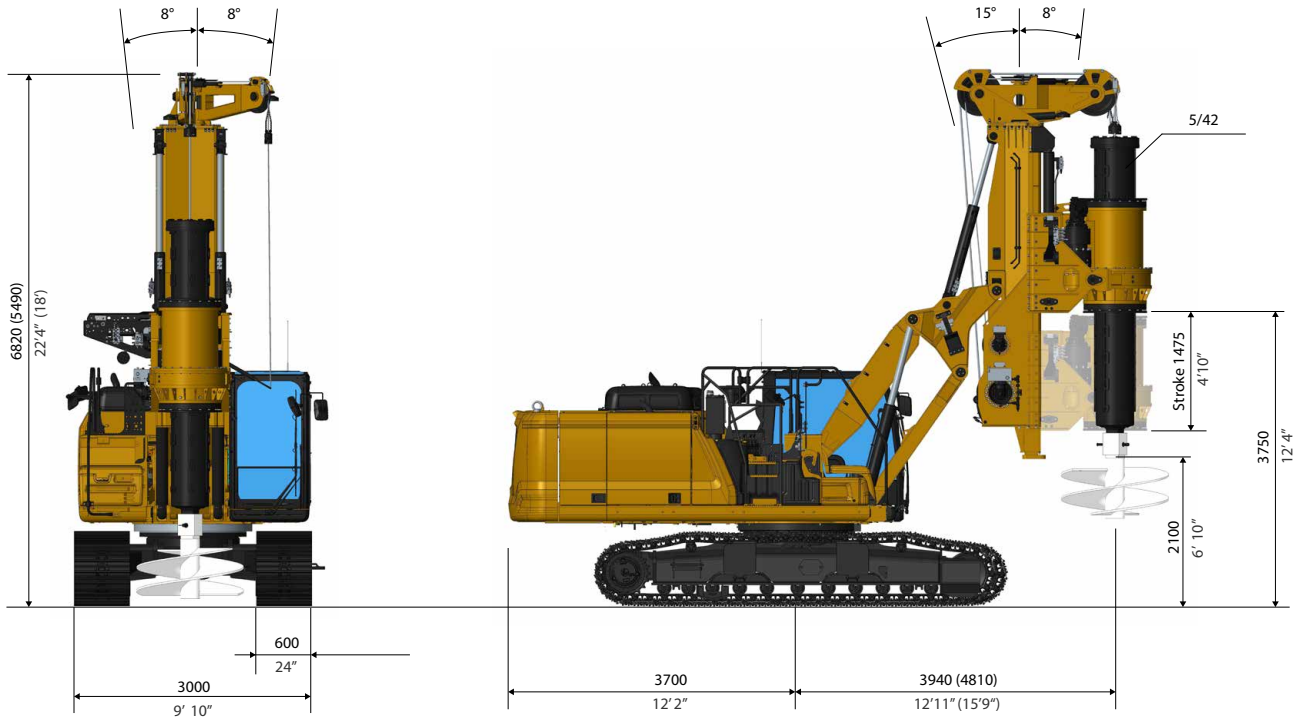

Operating Weight

Weight with 5/42 KB 39.3 ton 86700 lb

Transport Weight

Weight with 5/42 KB 39.3 ton 86700 lb

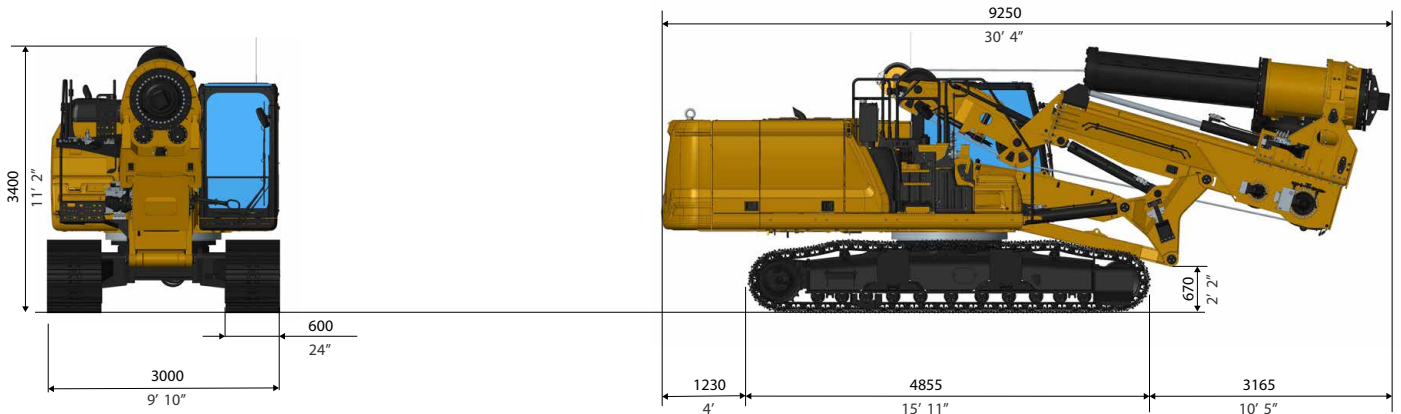

MAIN STANDARD EQUIPMENT

- Multifunctional HPM Computer
- Travel Alarm
- Cameras
- Automatic Mast Verticalization
- Auto Alignment with memory function

- Rotary Speed Control
- 10 Gears System
- Remote Diagnostics/Updates
- Removable Counterweight

OPTIONAL EQUIPMENT

- Extendable Undercarriage
- Aux. Swing Brake
- Casign Oscillator Predisposition
- Universal Casing Joint
- Walking Platform
- Remote Control
- Self Erecting Counterweight
- FOPS cab
- Biodegradable Hydraulic Oil
- Central Lubrication System
- Long Mast Kit
- CFA Kit

Design developments and process improvements may require the specification and materials to be updated and changed without prior notice or liability.

These and the technical data are provided as indicative information only, with any errors and misprints reserved.